

Roll No.

--	--	--	--	--	--	--	--	--	--	--	--	--	--	--	--	--	--	--	--

Total No. of Pages : 02

Total No. of Questions : 09

B.Tech.(ECE) (E-I 2012 to 2019) (Sem.-6)

DIGITAL SYSTEM DESIGN

Subject Code : BTEC-904

M.Code : 71233

Time : 3 Hrs.

Max. Marks : 60

INSTRUCTIONS TO CANDIDATES :

1. SECTION-A is COMPULSORY consisting of TEN questions carrying TWO marks each.
2. SECTION-B contains FIVE questions carrying FIVE marks each and students have to attempt any FOUR questions.
3. SECTION-C contains THREE questions carrying TEN marks each and students have to attempt any TWO questions.

SECTION-A

1. Answer briefly :

- (a) What is combinational logic circuit?
- (b) What is difference between PLA and PAL?
- (c) Explain the JK flip flop excitation table.
- (d) Define synchronous sequential circuit.
- (e) Write two limitations of finite state machine.
- (f) What is mealy machine?
- (g) What are the rules for the conversion of state diagram to an ASM chart?
- (h) What is Hazards?
- (i) State the purpose of programmable logic devices.
- (j) Explain AND PLD notation.

SECTION-B

2. Design and explain 4 to 1 channel multiplexer.
3. Explain the differences among a truth table, a state table, a characteristic table, and an excitation table. Also, explain the difference among a Boolean equation, a state equation, a characteristic equation, and a flip-flop input equation.

4. Differentiate Moore and Mealy machines.
5. Draw the block diagram of Asynchronous Sequential circuits and explain it.
6. Explain how to remove hazards? For a circuit shown below draw a hazards free circuit.

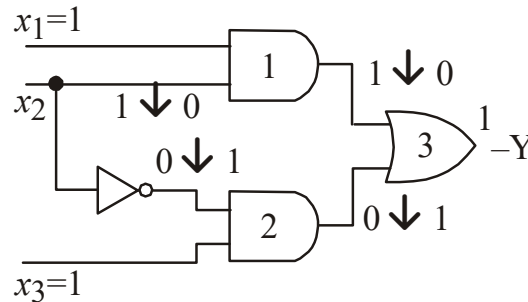

(a) AND-OR circuit

SECTION-C

7. A sequential circuit has two JK flip-flops A and B and one input x . The circuit is described by the following flip-flop input equations :

$$J_A = x \quad K_A = B$$

$$J_B = x \quad K_B = A'$$

- (a) Derive the state equations $A(t+1)$ and $B(t+1)$ by substituting the input equations for the J and K variables. (7)
- (b) Draw the state diagram of the circuit. (3)
8. Draw and explain the general structure of PLDs. Draw a simple four-input, three-output PAL derive. (7+3)
9. Convert the state diagram of Fig. below to ASM chart. (10)

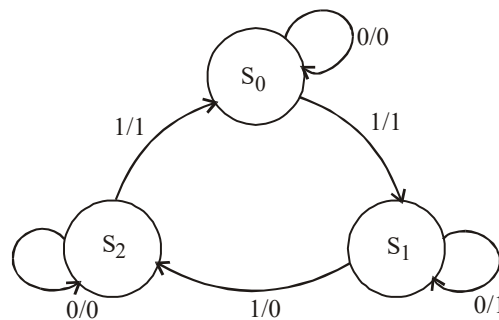

NOTE : Disclosure of Identity by writing Mobile No. or Making of passing request on any page of Answer Sheet will lead to UMC against the Student.